



# 4425 Combine



## TECHNICAL MANUAL 4425 Combine

TM4417 (01JUN89) English

**John Deere Werke Zweibrücken**  
**TM4417 (01JUN89)**

LITHO IN U.S.A.  
ENGLISH

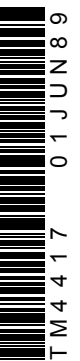



# 4425 COMBINE TECHNICAL MANUAL TM-4417 (JUN-89)

## CONTENTS OF THIS MANUAL IN SECTIONS

### **SECTION 10 – GENERAL**

- Group 05 – General Specifications
- Group 10 – Diagnosing and Testing Procedures
- Group 15 – Tune-Up and Adjustment
- Group 20 – Clamping Ring Bearings
- Group 25 – Drive Belts
- Group 30 – Drive Chains

### **SECTION 20 – ENGINE – REPAIR**

- Group 05 – Engine Removal
- Group 10 – Cooling System

### **SECTION 30 – FUEL/AIR INTAKE SYSTEM – REPAIR**

- Group 05 – Air Intake and Exhaust Systems
- Group 10 – Diesel – Fuel System
- Group 15 – Speed Control Linkage

### **SECTION 40 – ELECTRICAL SYSTEM – REPAIR**

- Group 05 – Wiring Harnesses and Connectors
- Group 10 – Starting motor
- Group 15 – Alternator
- Group 20 – System Components
- Group 25 – Low Shaft Speed Monitor
- Group 30 – HARVESTRAK™ Combine Monitor

### **SECTION 50 – POWER TRAIN – REPAIR**

- Group 05 – POSI-TORQ™ Ground Drive – Upper Unit
- Group 10 – POSI-TORQ Ground Drive – Lower Unit
- Group 15 – Clutch Control
- Group 20 – Clutch
- Group 25 – Four-Speed Transmission
- Group 30 – Final Drives

### **SECTION 60 – BRAKES AND REAR AXLE – REPAIR**

- Group 05 – Power Steering
- Group 10 – Rear Axle and V-Support
- Group 15 – Parking Brake
- Group 20 – Brakes Control
- Group 25 – Brakes

### **SECTION 70 – HYDRAULIC SYSTEM – REPAIR**

- Group 05 – Main Hydraulic Reservoir
- Group 10 – Main Hydraulic Pump
- Group 15 – Main Hydraulic Control Valve
- Group 20 – Hydraulic Cylinders
- Group 25 – Accumulator and Gauge
- Group 30 – Hydraulic Reel Drive System
- Group 35 – Hydraulic Reverser Motor

### **SECTION 80 – SEPARATOR SHELL – REPAIR**

- Group 05 – Rear Hood
- Group 10 – Rear Axle

### **SECTION 90 – OPERATOR'S STATION – REPAIR**

- Group 05 – Air Conditioning – Compressor
- Group 10 – Air Conditioning – Components
- Group 15 – Air Conditioning – Service
- Group 20 – Pressurizer System
- Group 25 – Heating System
- Group 30 – Seat
- Group 35 – Cab

### **SECTION 100 – HEADERS – REPAIR**

- Group 05 – 200 Series Cutting Platform
- Group 10 – 40 Series Corn Head
- Group 20 – 50 Series Row-Crop Heads

### **SECTION 110 – HEADER AND FEEDER DRIVES – REPAIR**

- Group 05 – Header and Feeder Drives
- Group 10 – Header and Feeder Drives
- Group 15 – Hydraulic Reverser

CONT-ZI301AE-020589

**CONTENTS OF THIS MANUAL IN SECTIONS – CONTINUED**

**SECTION 120 – SEPARATOR/CLEANING UNIT – REPAIR**

- Group 05 – Separator Drive
- Group 10 – Threshing Cylinder Variable Drive
- Group 11 – Cylinder Drive Reduction Gear
- Group 15 – Threshing Cylinder
- Group 20 – Concave
- Group 25 – Beater Variable Drive
- Group 30 – Beater
- Group 35 – Straw Walkers
- Group 40 – Chaffer and Sieves
- Group 45 – Cleaning Fan
- Group 50 – Straw Chopper
- Group 55 – Straw Spreader

**SECTION 130 – ELEVATORS, GRAIN TANK AND UNLOADING AUGERS – REPAIR**

- Group 05 – Tailings Augers and Elevator
- Group 10 – Clean Grain Auger and Elevator
- Group 15 – Grain Tank Augers
- Group 20 – Unloading Auger and Housing

**SECTION 140 – DIAL-A-MATIC™ HEADER HEIGHT CONTROL – REPAIR**

- Group 05 – Electrical System
- Group 10 – Hydraulic System

**SECTION 220 – ENGINE – OPERATION AND TESTS**

- Group 05 – Cooling System

**SECTION 230 – FUEL AND AIR INTAKE SYSTEM – OPERATION AND TESTS**

- Group 05 – Air Intake System
- Group 10 – Diesel Fuel System

**SECTION 240 – ELECTRICAL SYSTEM – OPERATION AND TESTS**

- Group 05 – General Testing/Wiring Charts and Diagrams
- Group 10 – Starting Motor
- Group 15 – Alternator
- Group 20 – Low Shaft Speed Monitor
- Group 25 – HARVESTRAK Combine Monitor

**SECTION 250 – POWER TRAIN – OPERATION AND TESTS**

- Group 05 – POSI-TORQ™ Ground Drive
- Group 10 – Clutch Control
- Group 15 – Clutch
- Group 20 – Transmission

**SECTION 260 – STEERING/BRAKES – OPERATION AND TESTS**

- Group 05 – Power Steering – Operation
- Group 10 – Power Steering – Diagnosing Malfunctions
- Group 15 – Power Steering – Tests
- Group 20 – Brakes and Brakes Control

**SECTION 270 – HYDRAULIC SYSTEM – OPERATION AND TESTS**

- Group 05 – Hydraulic System Operation
- Group 10 – Diagnosing Malfunctions
- Group 15 – Hydraulic System

**SECTION 290 – OPERATOR'S STATION – OPERATION AND TESTS**

- Group 05 – Air Conditioning Operation
- Group 10 – Air Conditioning – Tests
- Group 15 – Pressurizer System

**SECTION 340 - DIAL-A-MATIC HEADER HEIGHT CONTROL – OPERATION AND TESTS**

- Group 05 – General information, Diagnosis
- Group 10 – Electrical System
- Group 15 – Hydraulic System
- Group 20 – Mechanical System

*NOTE: All information, illustrations and specifications contained in this technical manual are based on the latest information available at the time of publication.*

*The right is reserved to make changes at any time without notice.*

™ are John Deere trademarks.

**Thanks very much for your reading,  
Want to get more information,  
Please click here, Then get the complete  
manual**

**JustClickHere** 

**NOTE:**

**If there is no response to click on the link above,  
please download the PDF document first, and then  
click on it.**

**Have any questions please write to me:  
[admin@servicemanualperfect.com](mailto:admin@servicemanualperfect.com)**

## INTRODUCTION

This manual is part of a total service support program.

### FOS MANUALS – REFERENCE

Fundamentals of Service (FOS) Manuals cover basic theory of operation, fundamentals of troubleshooting, general maintenance, basic types of failures and their causes. FOS Manuals are for training new personnel and for reference by experienced technicians.

### TECHNICAL MANUALS – MACHINE SERVICE

Technical Manuals are concise service guides for specific machines. Technical Manuals are on-the-job guides containing only the vital information needed by an experienced technician.

### COMPONENT MANUALS – COMPONENT SERVICE

Component Technical Manuals are concise service guides for specific components. Component technical manuals are written as stand-alone manuals covering multiple machine applications.

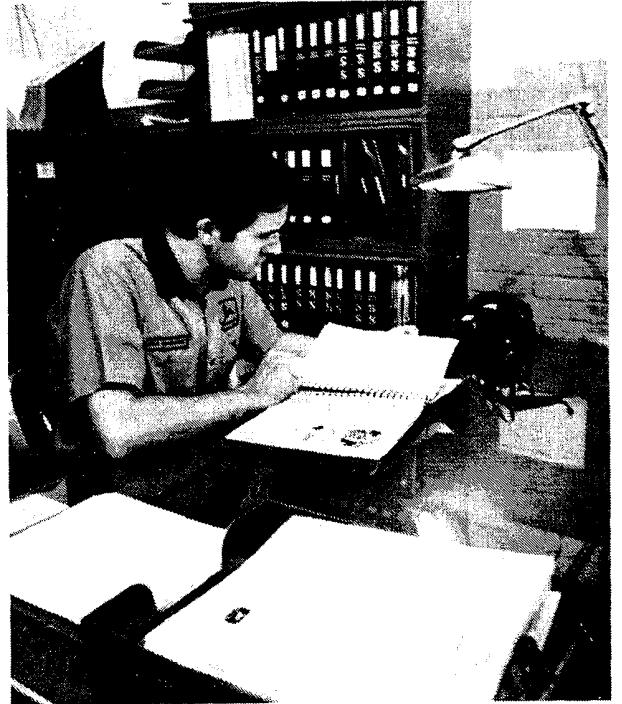

X2252N-ZI303AE-011085

## TECHNICAL MANUAL TABS

### INTRODUCTION

To fully utilize this manual, you must understand how it is organized. Only two tab colors are used – green and yellow, each representing a different type of information. Spend a minute reading this now and save many minutes of searching later.

**A-Green tabs**

**B-Yellow tabs**

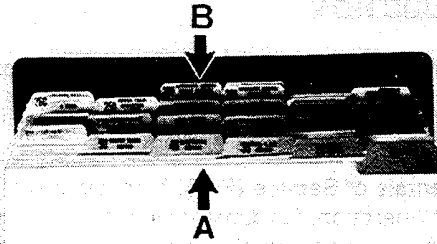

Z107392

Z107392-ZI304AE-011085

## GREEN TAB SECTIONS

The green tab sections are REPAIR sections, telling you how to repair components of the various systems.

Repair of a component includes:

- Removal from machine (if necessary)
- Disassembly
- Inspection
- Replacement of parts
- Assembly
- Adjustment
- Installation on machine (if necessary)

The numbers, used for the repair (green tab) sections, are part of an overall service publication numbering system. The numbers identify the same sections in the parts catalog, flat rate manual, service information bulletins and service training courses.

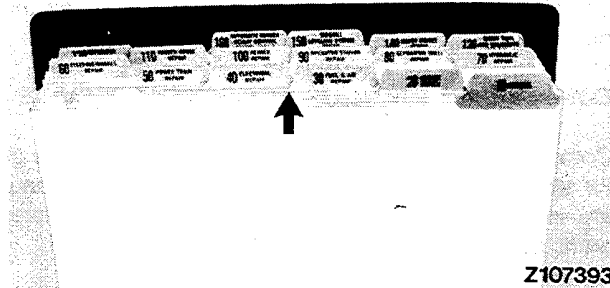

Z107393

Z107393-ZI304AE-011085

## YELLOW TAB SECTIONS

Each yellow tab section contains information on:

- System Operation
- System Tests

System operation explains how the system and its components work.

System tests tell you how to test the system and diagnose the problem.

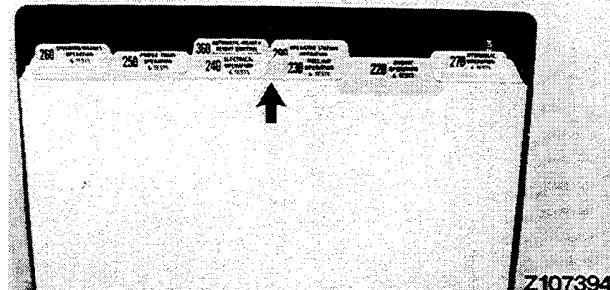

Z107394

Z107394-ZI304AE-011085

### TAB POSITIONS

Each green tab and its corresponding yellow tab have the same tab position. This helps you to quickly locate the related information.

**A-Green tab**

- Section 70
- Hydraulic Repair

**B-Yellow tab**

- Section 270
- Hydraulic Operation/Tests



Z107395-ZI305AE-011085

### THREE-STEP PROCEDURE

Use the following three-step procedure to locate the desired information.

1. Determine the type of information you need: Is it?

- A - Repair
- B - Operation
- C - Tests

2. Go to the appropriate section tab:

- Green - for Repair
- Yellow - for Operation or Tests

3. Use the Table of Contents on the first page of each section to locate the information.

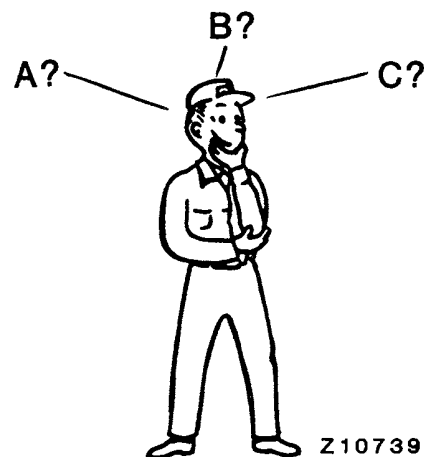

Z107396

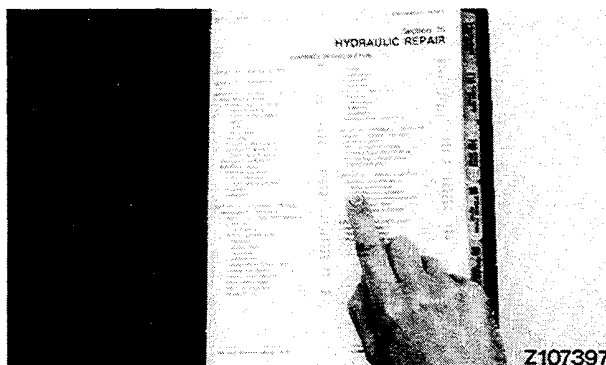

Z107396,Z107397-ZI305AE-011085



*Introduction*

140586

# Section 10 GENERAL

## CONTENTS OF THIS SECTION

### GROUP 05 – GENERAL SPECIFICATIONS

Specifications .....	10-05-1
Identification Plates .....	10-05-6
Dimensions .....	10-05-8
Standard Torques .....	10-05-10

### GROUP 10 - DIAGNOSING/TESTING PROCEDURES

Troubleshooting .....	10-10-1
-----------------------	---------

### GROUP 15 – TUNE-UP AND ADJUSTMENT

Engine Pre-Check .....	10-15-1
Engine Check and Adjustments .....	10-15-2
Engine Performance Test .....	10-15-3
Combine Checks and Adjustments .....	10-15-4

### GROUP 20 – CLAMPING RING BEARINGS

Bearings – General .....	10-20-1
Clamping Ring Bearings:	
– Removal .....	10-20-1
– Repair .....	10-20-1
– Install w/ Metal Housing .....	10-20-2
– Install w/ Cast Housing .....	10-20-3

### GROUP 25 – DRIVE BELTS

Belt wear .....	10-25-1
Inspect Belt Pulley .....	10-25-3
Sheave Alignment .....	10-25-3
Drive Belt Installation .....	10-25-4
Adjustment .....	10-25-4
Belt Dressing .....	10-25-5
Belt Cleaning .....	10-25-5
Belt Storage .....	10-25-6
Belt Maintenance .....	10-25-6

### GROUP 30 – DRIVE CHAINS

Chain Drives .....	10-30-1
Chain Locks .....	10-30-2
Safety Link Locks .....	10-30-3
Chain Maintenance .....	10-30-3
Chains w/ O-Ring Seals .....	10-30-3

INHA-ZI3101AE-011085

*Contents*

**SPECIFICATIONS**

**ENGINE**

Make .....	JOHN DEERE
Model .....	6359 DZ 04 (old) 6359 DZ 004 (new)
Bore .....	106.5 mm (4.2 in.)
Stroke .....	110 mm (4.33 in.)
Horsepower:	
(gross, as per SAE J816b) .....	117 hp
(as per DIN 70020) .....	115 DIN-PS (84kW)
Number of Cylinders .....	6
Compression Ratio .....	16.8 to 1
Minimum Compression at Starter Cranking Speed (180 rpm) .....	2400 kPa (24 bar; 342 psi)
Displacement .....	5883 cm <sup>3</sup> (359 cu.in.)
Flywheel Torque at 1300 rpm .....	370 Nm (272 ft-lb)
Full Load Speed .....	2500 rpm
Slow Idle speed .....	1200 to 1300 rpm
Fast Idle Speed .....	2675 to 2725 rpm
Firing Order .....	1 - 5 - 3 - 6 - 2 - 4
Type of Lubrication .....	Gear Pump Force Feed
Valve Clearance (cold or hot):	
Intake .....	0.35 mm (0.014 in.)
Exhaust .....	0.45 mm (0.018 in.)
Make of Injection Pump .....	STANADYNE™ DB2 RE 12323
Injection Nozzles .....	STANADYNE™ Four-Hole

SPECI-ZI31005AE-301086

*Specifications*

**SPECIFICATIONS, CONTINUED**

**ELECTRICAL SYSTEM**

Voltage .....	12 Volts
Alternator .....	65 Amps (Bosch)
Starting Motor .....	3 kW (4 hp) (Bosch)
Ether Starting Aid .....	Standard

**CAPACITIES**

Fuel Tank .....	300 l (80 U.S.gal.)
Engine Crankcase: (Incl. Oil Filter) .....	11 l (3 U.S.gal.)
Transmission Case .....	6.6 l (1-3/4 U.S.gal.)
Final Drives (Each) .....	2.1 l (4-1/2 U.S.pt)
Hydraulic System:	
a) Incl. Lines & Components .....	25 l (6.6 U.S.gal.)
b) Hydr. Oil Reservoir .....	20 l (5.3 U.S.gal.)
Hydr. Reel Drive System:	
a) Incl. Lines & Components .....	12 l (3.2 U.S.gal.)
b) Hydr. Oil Reservoir .....	10 l (2.6 U.S.gal.)
Cooling System .....	25 l (6.6 U.S.gal.)

SPECI-ZI31005BE-301086

**SPECIFICATIONS, CONTINUED**

**COMBINE DIMENSIONS AND WEIGHT**

Length w/o Header .....	7.18 m (23 ft 6 in.)
Height .....	3.84 m (151 in.)
Tread Width (Front):	
– (Standard) .....	223 to 248 cm (88 to 98 in.)
– (w/ Axle spacers) .....	263 to 288 mm (104 to 114 in.)
Wheel Base .....	372 cm (146 in.)
Weight less Header .....	7 130 kg (15 719 lb)
Turning Radius .....	
– (Standard) .....	5.58 m (220 in.)
– (w/ Axle spacers) .....	5.93 m (233 in.)

**FAN**

Type .....	Blower fan
Drive Adjustment .....	V-Belt, infinitely variable, mechanical adjustment
Fan Blade Diameter .....	580 mm (22.5 in.)
Number of Fan Blades .....	5
Speed Range .....	340 ±20 to 1060 ±60 rpm
Adjustable Windboards .....	2

Specifications

**SPECIFICATIONS, CONTINUED**

**GRAIN TANK**

Capacity (Standard) .....	4400 l	(125 bu.)
Discharge Volume .....	3250 l/min. 540 l/min.	(92 bu./min.) (1.5 bu./sec)

**TRANSMISSION**

Standard .....	Automotive, 4 speeds forward, 1 speed reverse,
Ground Speed Drive .....	POSI-TORQ
Type .....	Infinitely variable in each gear

**BRAKES**

Foot Brakes .....	Hydraulically-actuated disk brakes, also acting on individual wheels
Parking Brake .....	Mechanical disk brakes

**STEERING SYSTEM**

Type .....	Hydrostatic steering
------------	----------------------

**TIRE PRESSURES:**

- Front Axle (23.1-26 10PR) .....	166 kPa	(1.66 bar; 24 psi)
- Rear Axle (10.0-16 8 PR) .....	310 kPa	(3.1 bar; 45 psi)

**GROUND SPEEDS**

(with 23.1-26 10 PR tires)	
1st Gear .....	1.5 to 3.4 km/h (0.9 to 2.1 mph)
2nd Gear .....	3.0 to 6.9 km/h (1.9 to 4.3 mph)
3rd Gear .....	5.4 to 12.5 km/h (3.4 to 7.8 mph)
4th Gear .....	10.8 to 25.0 km/h (6.7 to 15.5 mph)
Reverse Gear .....	3.4 to 7.8 km/h (2.1 to 4.8 mph)

**HEADER DRIVE SHAFT**

Speed Ranges:

Inner Chain Position .....	568 rpm
Outer Chain Position .....	497 rpm

SPECI-ZI31005DE-011085

*Specifications*

**SPECIFICATIONS, CONTINUED**

**CYLINDER**

Type .....	Rasp bar	
Width .....	1040 mm	(41 in.)
Diameter .....	610 mm	(24 in.)
Drive (Standard) .....	V-belt, hydr. adjustment,	POSI-TORQ
Speed Range .....	380 to 1100 rpm	
Number of Rasp Bars and Filler Plates .....	8	

**CONCAVE**

Number of Bars .....	14	
Width .....	1040 mm	(41 in.)
Stone Trap .....	Regular	
1st De-awning Plate .....	Spare part only	

**BEATER**

Type .....	Box cylinder	
Width .....	1040 mm	(41 in.)
Diameter .....	300 mm	(15 in.)
Speed .....	850 to 880 rpm	

**SHAKER SYSTEM**

Length .....	3.65 m	(144 in.)
Total Walker Area .....	3.80 m <sup>2</sup>	(5890 sq-in.)
Total Separating Area .....	4.30 m <sup>2</sup>	(6665 sq-in.)

**CLEANING UNIT**

Type .....	Reciprocating chaffer and sieves w/ blower fan
------------	---

**CHAFFER W/ EXTENSION**

Type (Standard) .....	Laminated sheet metal, adjustable – Deep Tooth Regular Tooth – Spare part only	
Width .....	97 cm	(38 in.)
Length (w/ Extension) .....	197 cm	(77.5 in.)
Area (w/ Extension) .....	1.90 m <sup>2</sup>	(2960 sq-in.)

**SIEVES**

Type (Standard) .....	Laminated sheet metal,adj.	
Width .....	97 cm	(38 in.)
Length .....	152 cm	(60 in.)
Area .....	1.58 m <sup>2</sup>	2325 sq-in.)
Total Sieve Area .....	3.41 m <sup>2</sup>	(5285 sq-in.)
Dividers:		
– On Chaffer .....	Standard installed	
– On Grain Return Pan .....	Standard installed	

SPECI-Z131005EE-011085



## SERIAL NUMBER PLATES

Serial numbers, identifying combine components or assemblies, are stamped on components or factory serial number plates. These numbers are required when ordering combine or component replacement parts. To ensure that you always have these numbers at hand, enter the appropriate serial numbers in the spaces provided in each illustration.

SEROM-1055AZE-311084

## PRODUCT IDENTIFICATION NUMBER

The product identification number plate is located on the right-hand side of the operator's platform.

*NOTE: In addition, the last seven digits of the product identification number are stamped on the right-hand frame (B) above the fan.*

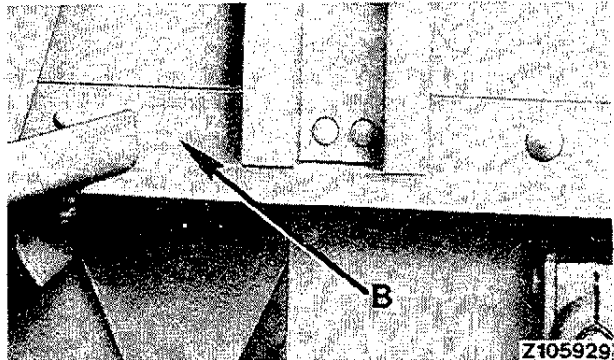
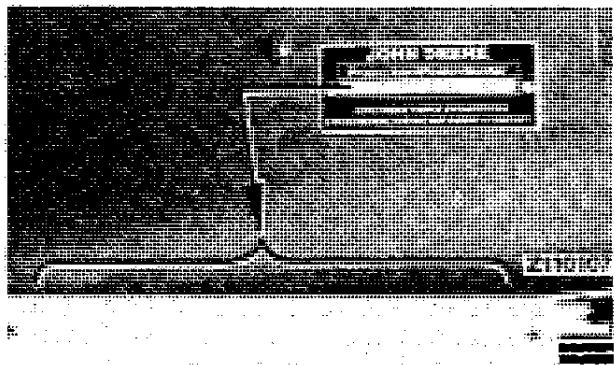

Z110107.Z105929-4425AZE-300985

## ENGINE SERIAL NUMBER

The engine serial number plate is located on the right-hand side of the engine block, near the mechanical fuel transfer pump.

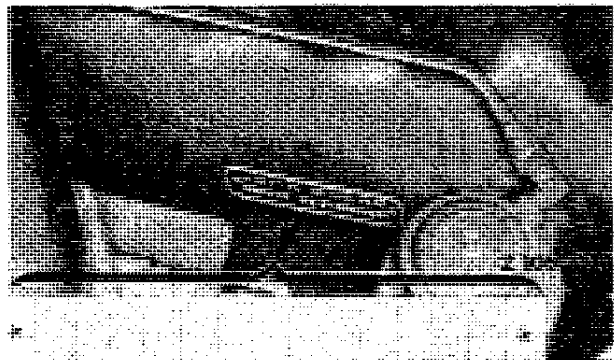

Z105831-4425AZE-300985

### OPERATOR'S CAB SERIAL NUMBER

The operator's cab serial number plate is located on the inner side of the left-hand panel.

*NOTE: The operator's cab serial number is identical with that of the air conditioning system.*

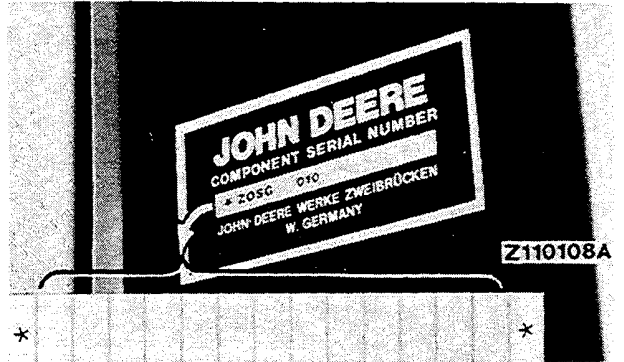

Z110108-4425AZE-300985

### AIR CONDITIONING SYSTEM SERIAL NUMBER

The air conditioning system serial number plate is located on the right-hand rear corner of frame.

*NOTE: The air conditioning system serial number is identical with that of the operator's cab.*

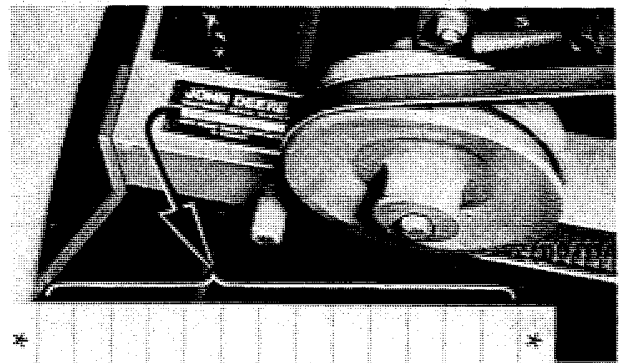

Z110111-4425AZE-300985

### STRAW CHOPPER SERIAL NUMBER

The straw walker serial number plate is located on left-hand outer side of straw chopper.

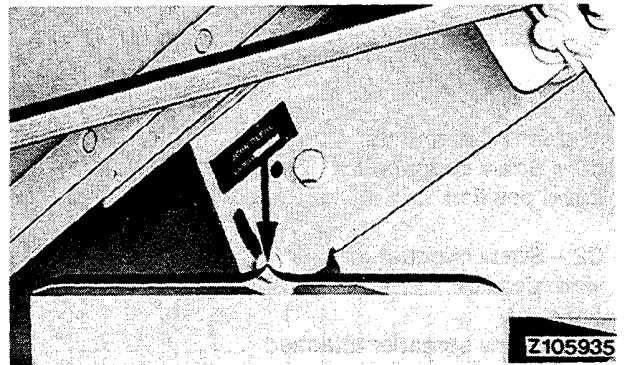

Z105935-1065AZE-300985

**COMBINE DIMENSIONS**

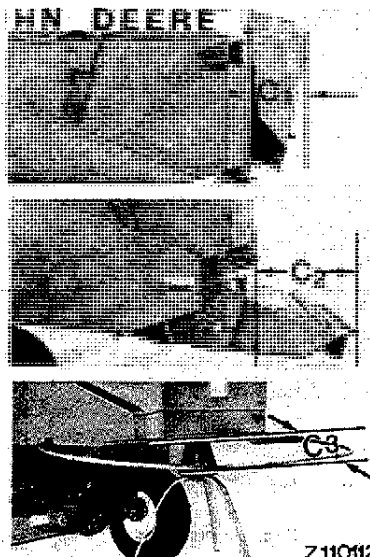
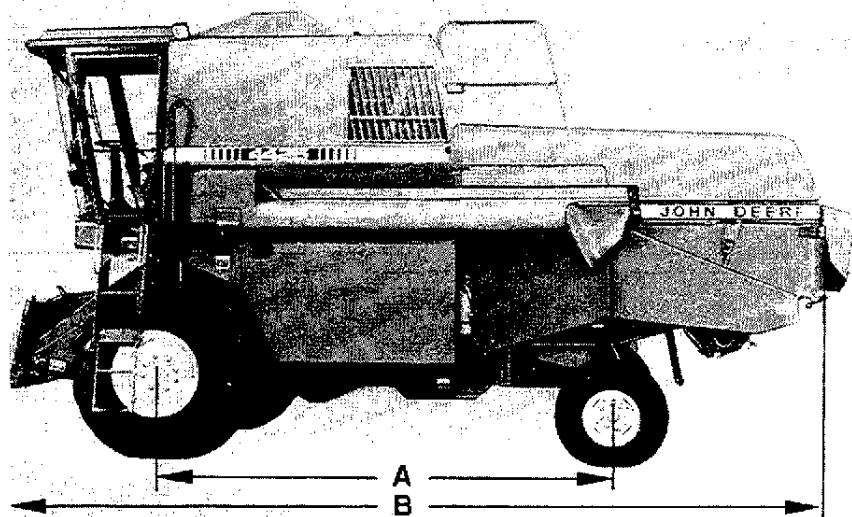

Z110112

**Lengths**

Length without Header:

A – Wheel Base .....	3.72 m (12 ft. 2 in.)
B – Total Length: .....	7.18 m (23 ft. 7 in.)

Add for Attachments:

C1 – Straw chopper in travel position .....	+ 33 cm (+ 13 in.)
C2 – Straw chopper in work position .....	+ 48 cm (+ 19 in.)
C3 – Straw spreader attached .....	+ 66 cm (+ 26 in.)

Z110112-Z13'005AE-011085

COMBINE DIMENSIONS – CONTINUED

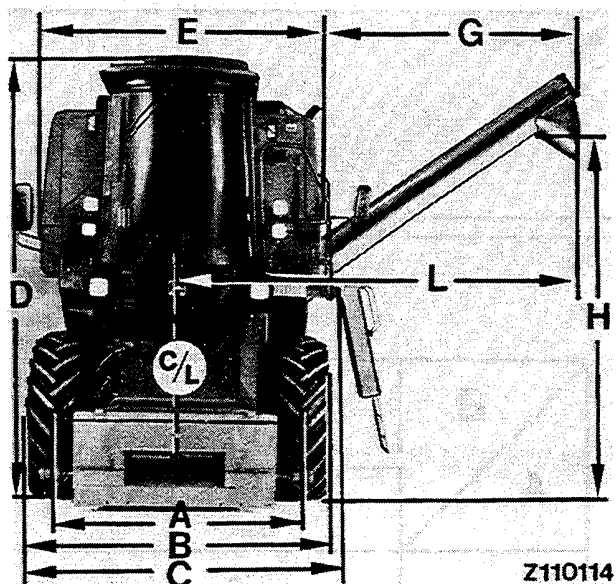
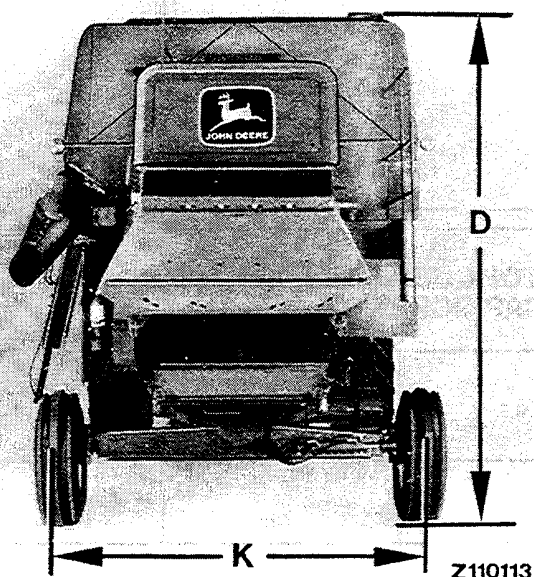

Widths and Heights

Inner Rim Position:

A – 2234 mm	.....	(88 in.)
B – 2779 mm	.....	(110 in.)
C – 2929 mm	.....	(115 in.)

Outer Rim Position:

A – 2480 mm	.....	(98 in.)
B – 3025 mm	.....	(119 in.)
C – 3052 mm	.....	(120 in.)

Inner Rim Position w/ Axle Spacers:

A – 2638 mm	.....	(104 in.)
B – 3183 mm	.....	(125 in.)
C – 3236 mm	.....	(127 in.)

Outer Rim Position w/ Axle Spacers:

A – 2884 mm	.....	(114 in.)
B – 3429 mm	.....	(135 in.)
C – 3514 mm	.....	(138 in.)
6		
D – 3.81 to 3.84 m	.....	(150 to 151 in.)
E – 2.69 m	.....	(8 ft. 9 in.)
G – 2.92 m	.....	(9 ft. 7 in.)
H – 3.60 m	.....	(11 ft. 11 in.)
K – 2108 to 2821 mm	.....	(83 to 111 in.)
in increments of 102 mm (4 in.)		
L – 4.35 m	.....	(14 ft. 3 in.)

Z110113,Z110114-ZI31005AE-011085